

Manganese Greensand

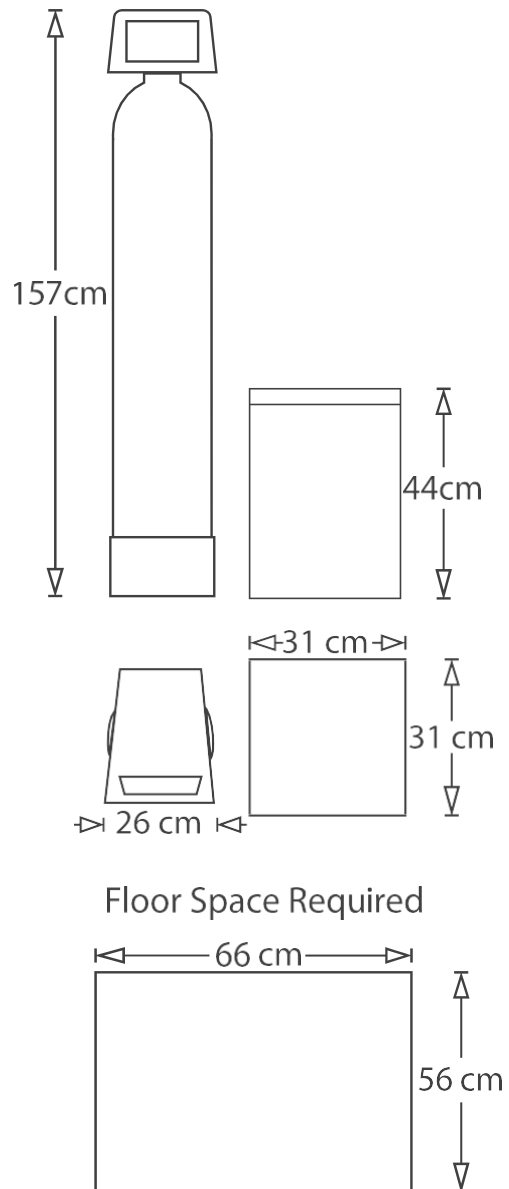

Information

This unit removes iron and manganese to a combined level of 6 milligrams per litre

The pH of your water must be 7 or above

What You Get

- 1 off 225 740 Osminics Valve
- 1 off 10x54" Fibreglass Vessel
- 1 off 1 Cubic Ft. Manganese
- 1 off 35L Premix Container
- 1 off Permixon

Important

This unit is recommended for your water at the time of testing, if the bacterial content of your water changes over time it may be necessary to upgrade or invest in a new unit.