

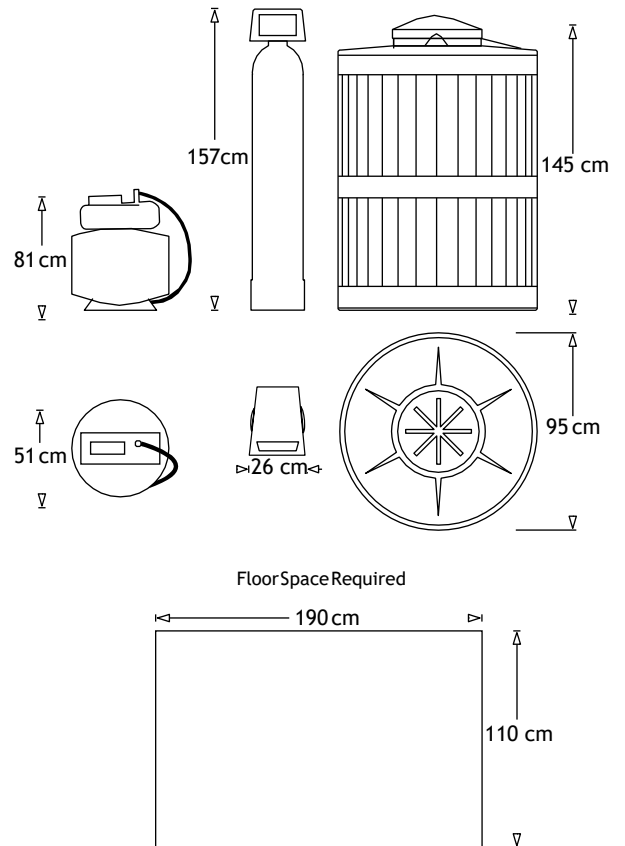

Birm Tank System



What It Does

This filter removes iron and manganese to a combined level of 10 milligrams per litre.

When calculating your levels you must multiply the levels of manganese by 2.

The pH of your water must be 7.5 or over.

What You Get

- 1 off 263/740 Autotrol Valve
- 1 off 10" X 54" Fibreglass Vessel
- 1 off 1.5 Cubic Ft. Birm
- 1 off 200 Gallon Settlement Tank
- 1 off 1HP Booster Pump

*Please note that this unit is recommended to you for your water at the time of testing, if the mineral content of your water changes over time it may be necessary for an upgrade or to invest in a new unit.