



www.perfectwater.ie
Kinetico[®]
water systems

premier

COMPACT

Water Softener

Installation and User Manual

ENG



 Kinetico[®]



The Premier Compact Water Softener has been Tested and Certified by WQA under NSF/ANSI 61 for Materials Safety Requirements Only. Not Certified for Contaminant Reductions or Structural Integrity by WQA.

For more information about Kinetico
visit **www.kinetico.co.uk**

Contents

Safety information	4
Contents of box	6
Specifications	6
How to set the XP	7
Getting to know the softener	9
Pre-installation check list	10
Installation instructions	12
Review	14
Commissioning instructions	15
Useful information	17

Safety information

Read all information carefully prior to installing and using the water softener.

Qualified Installer



INSTALLER

Kinetico recommends that a qualified installer performs the installation. Failure to install the system as instructed could invalidate the Limited Warranty.

Water Pressure

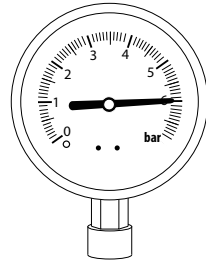

Do not install if the supply water pressure exceeds 6 BAR (87 psi), unless a suitable pressure regulating valve has been installed on the softener water supply.

Water Temperature

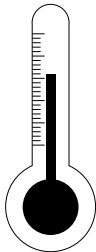

Do not install the Kinetico softener in an area where the water temperature can exceed 24°C or cause the unit to freeze. Freezing temperatures will damage the system.

Overflow

VERY IMPORTANT:

Where a cabinet overflow could cause damage, you must install a 1/2" I.D. hose to the barbed fitting on the cabinet and run to a suitable outlet that is visible and capable of taking the overflow (i.e. through the outside wall).

Make sure the hose does not go higher than the barbed fitting as the water will flow away using gravity.

Copper/Plastic Pipework

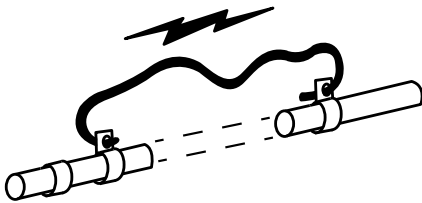

Where copper/plastic pipework is used, Kinetico advises adherence to the regulatory requirements to ensure adequate earth bonding is provided.

Intended Use

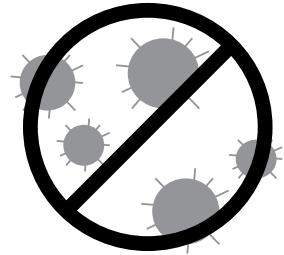

Not intended to be used for treating water that is micro-biologically unsafe or water that has an unknown quality, without adequate disinfection before or after the system.

Conform to Regulations

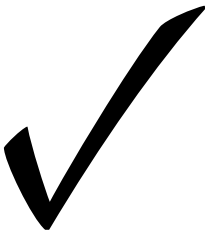

You must ensure that the installation conforms to local plumbing codes and regulations. Note: Refer to separate instructions for important WQA certification information.

Plumbing Schematic

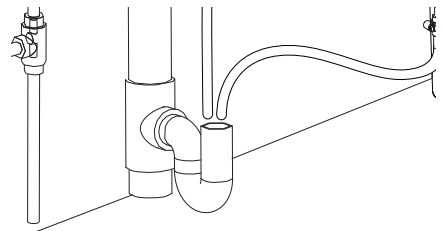

Please refer to the plumbing schematic on page 10 before commencing an installation.

Contents of box

Identify the following parts before proceeding.



1 x in/out retaining bracket and pin

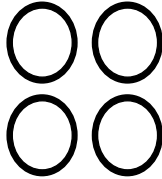

4 x o-ring

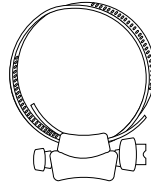

Jubilee clip

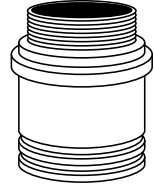

2 x 3/4" BSP in/out adaptor

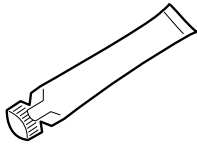

1 x 2cc silicone tube

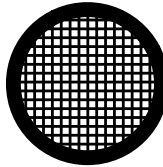

2 x 3/4" screened washers

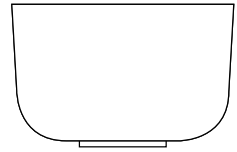

1 x blanking plate

Specifications

Meter Disc	A	B	C	D	E	F	G	H	I	*	J	*	K	*	L	*	M	*
Max hardness in PPM	108	115	123	132	143	156	171	191	215	230	247	266	290	318	352	394	449	523
Litres between regenerations	1420	1328	1235	1143	1051	958	866	773	681	635	589	543	496	450	404	358	312	266

Cabinet dimensions (h x w x d)	498 x 219 x 468 mm
Salt used per regeneration	0.34 kg
Regeneration time	11 minutes
Flow rate @ 1 bar pressure drop	22.7 l/min
Pipe connections - in/out	3/4" BSP
Min/max operating pressure	1.8 - 6 bar
Min/max operating temperature	2 - 24°C

How to set the XP

1 Unlock the XP:

Ensure the system has reset by putting a philips screwdriver in the actuator (see page 17). Whilst firmly pushing down, turn the screwdriver at least two full rotations. Check the arrow is in the correct position, shown below.

Incorrect

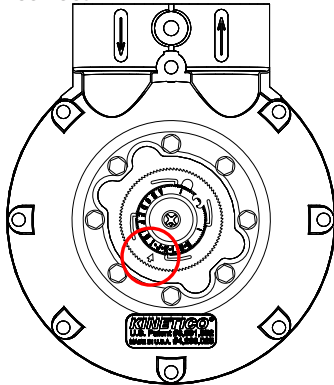

Correct

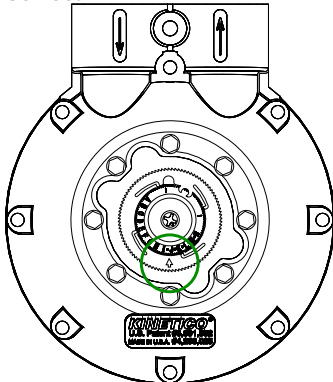

2 Select the setting using the chart:

Determine the XP meter setting from the chart on previous page:
a: read across to hardness level
b: read to the top for setting.

3 Set the XP meter:

Adjust the XP meter setting by using an appropriately sized flat-headed screwdriver to push down and rotate the hardness adjustment knob.

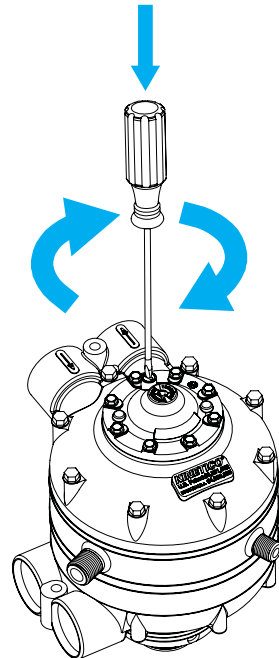

4 Confirm the setting:

Set the arrow to the desired position.

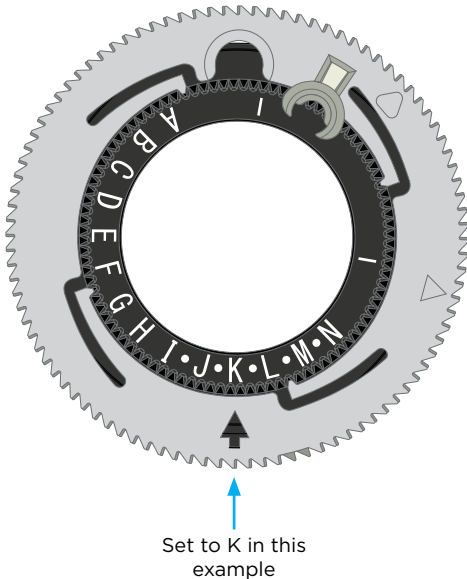

Please note: NEVER set XP with the arrow aligned anywhere in the black section of the meter disc. The softener will not meter properly.

5 Release the XP adjuster:

Release adjuster, making sure knob returns to an up position.

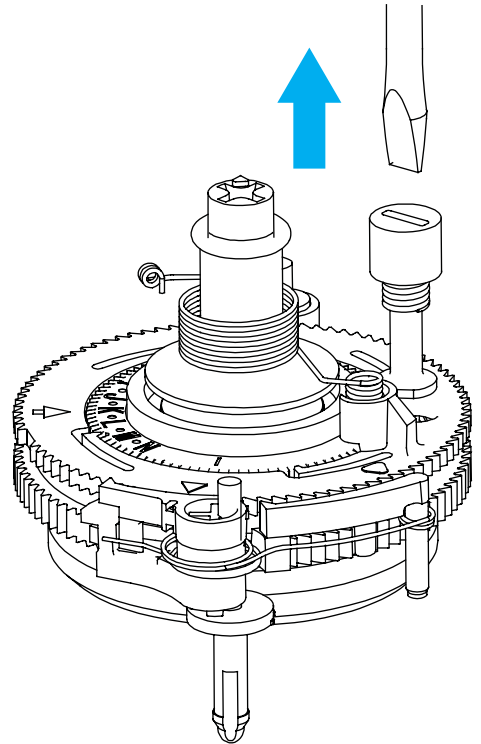

Getting to know the softener

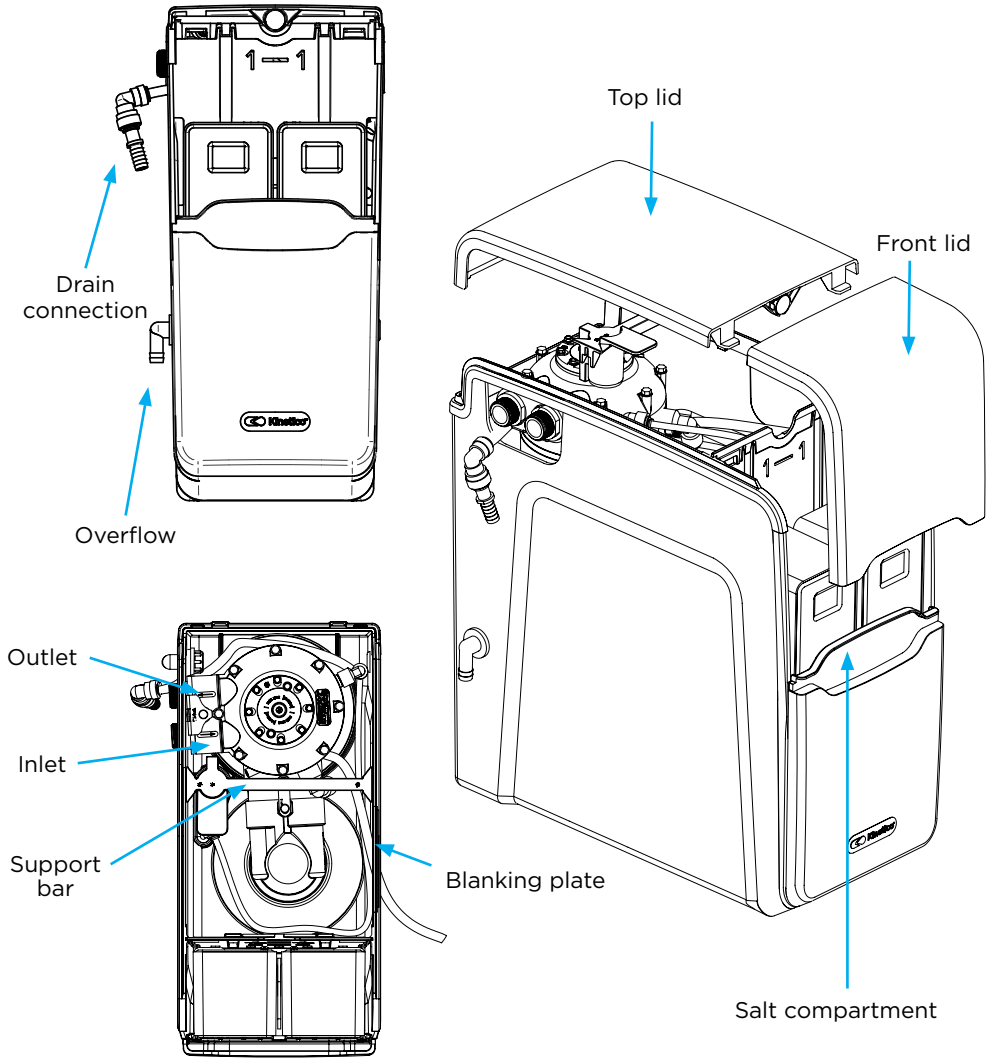

Pre-installation check list

When determining the location of the softener, the following should be considered:

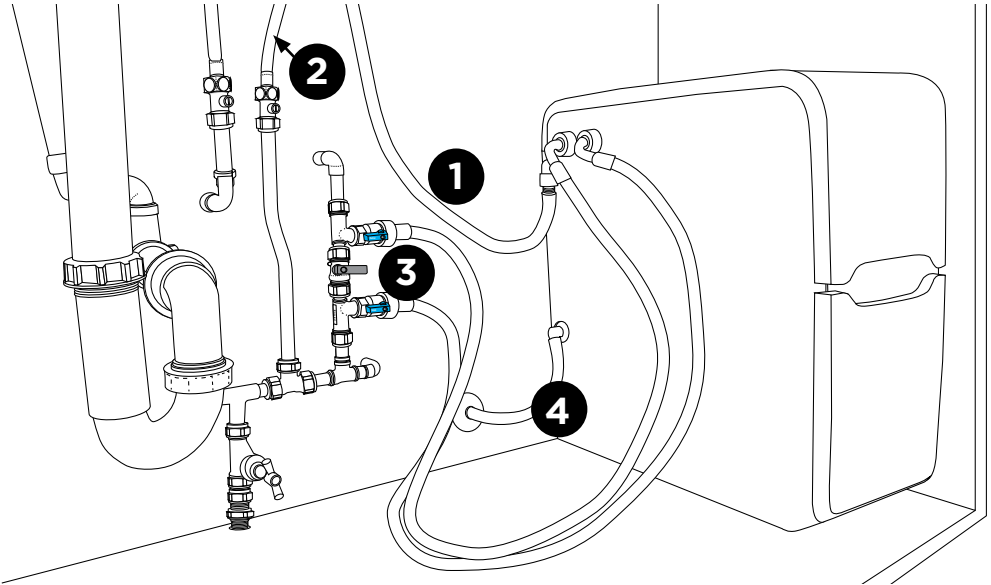

- 1** Drain line to air gap with internal trap
- 2** Mains water (see WRAS guidance note 09-07-01)
- 3** By-pass assembly
- 4** Overflow to outside/visable location

Dimensions - h 498mm x w 219mm x d 468mm

Installation will vary but should consist of:

- a:** A pressure regulating valve on the water supply to the softener where the incoming pressure exceeds 6 bar.
- b:** A non-return valve on the mains water supply to the softener. If using a Kinetico supplied installation kit, a non-return valve is built into the inlet tee.
- c:** A by-pass assembly which enables the softener to be isolated from the water supply for maintenance and service. This also maintains the water supply when the system is disconnected.
- d:** A drain line from the softener to a waste pipe through an appropriate air gap. The drain must comply with local plumbing codes.
- e:** An overflow run to a suitable outlet that is visible.

Ensure you have the following:

- a:** Means of constructing a by-pass which consists of:
3 valves,
Tee pieces,
Single check valve

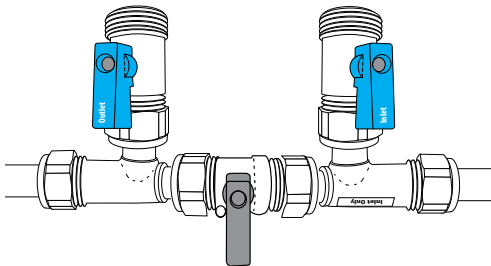

- b:** Connections for the inlet and outlet, either by means of flexible pressure rated hoses or by direct pipework.

Connections on the softener are 3/4" BSP male threaded fittings.

- c:** 1/2" ID hose for both the overflow and the drain.
- d:** Jubilee clip for the drain line.

Installation instructions

Caution: Do not solder any fitting while connected to the unit adaptors.

Care should be taken during the installation process to ensure solder and flux do not come in contact with any of the components.

1 Locate:

- a: Ensure the unit can be positioned on a flat surface.
- b: If sand, silt or turbidity are present in the water supply, a pre-filter should be installed before the water softener.

Please note: For ease of installation the softener can be installed with the connections on the left or right side of the cabinet by reversing the components.

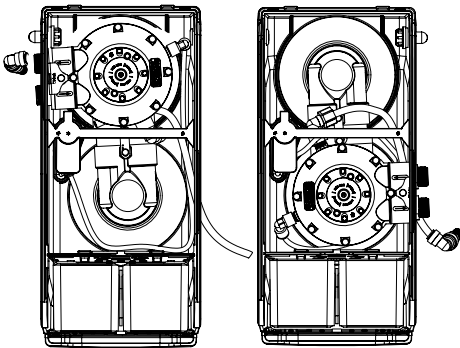

2 Insert blanking plate:

Insert the blanking plate into the outlet which is not in use.

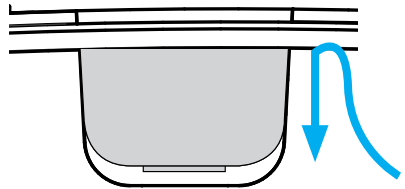

Lift up into position, then drop the plate down into the slot.

3 Test water pressure:

Test incoming pressure to the unit. **A pressure regulating valve will be required if the pressure is above 6 bar.**

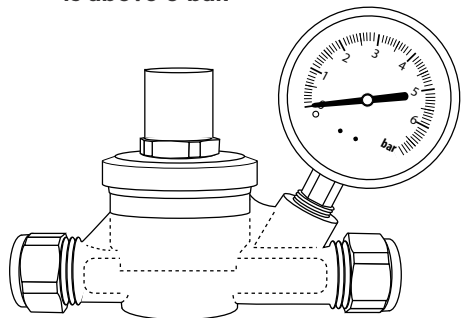

4 Install:

Plumb pipework as necessary to accommodate a by-pass assembly.

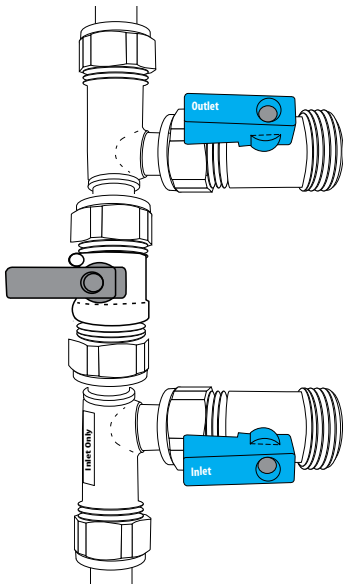

Please note:

Verify installation complies with regional water regulations before continuing. Consult WRAS Guidance Note 09-07-01 for advice.

5 Flush:

After plumbing is complete, but before connecting to water softener, flush both inlet and outlet lines and allow water to rinse out any debris.

6 Fit inlet/outlet connection:

When using the Kinetico blending by-pass valve, consult separate installation instructions. Please note, the orientation of the valve will determine which connection is used as the inlet. Or, follow the process below:

- a: Fit 2 o-rings to each in/out adaptor then lubricate with the supplied silicone grease.

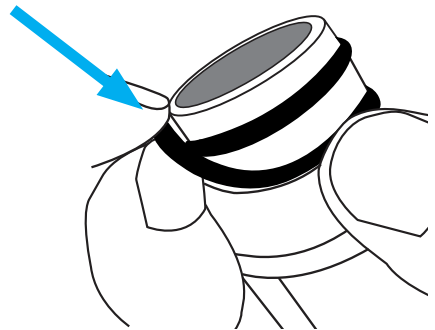

- b: Connect inlet/outlet adapters to supply and return hoses remember to use the washers.
- c: Install adapters into control valve in/out ports, ensuring that they are fitted into the correct ports (see flow arrows on valve for reference).
- d: Attach the retaining bracket and pin to the control valve.

7 Run drain line:

- a:** Run a drain line to a discharge point, checking for any obstructions or possible kinks.

FOLLOW LOCAL PLUMBING CODES.

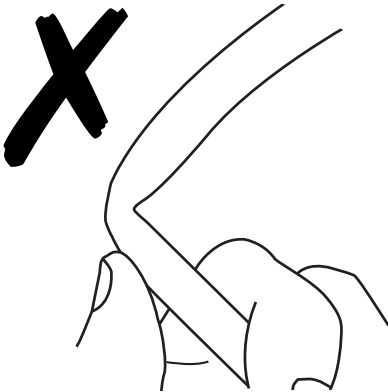

- b:** Before connecting the drain line to the unit, slide on the stainless steel jubilee clip.
- c:** Push the drain line onto the barbed fitting and tighten the jubilee clip securely.

Please note:

Drain lines must not run more than 2.4m up or exceed a total of 9m. The drain line must not be restricted or kinked.

Review

1 Pressure:

If a pressure regulating valve has been fitted, ensure it has been correctly set to 6 bar.

2 Drain line:

Ensure the drain line is securely attached, has no restrictions or kinks, uses an airgap and is fully compliant.

3 Overflow:

Ensure the overflow has no kinks, is securely attached and that water is able to fall away with gravity.

4 Inlet/Outlet connections:

Ensure the hoses/plumbing are attached securely, using the washers provided, and are firmly held in place using the retaining bracket and pin.

5 By-pass assembly:

Ensure the inlet and outlet valves are closed and that the by-pass valve is open.

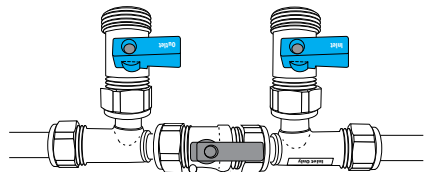

Commissioning instructions

1 Pressurise:

With the water to the property restored, slowly open the inlet valve. Water may run to drain until the unit is fully pressurised.

2 Fill the brine tank with water:

Allow the brine tank to fill with water until the brine valve shuts off.

The water level should be approximately 25mm over the white grid plate.

TIP:

If the water stops short, fill until the water is approximately 25mm above the white grid plate.

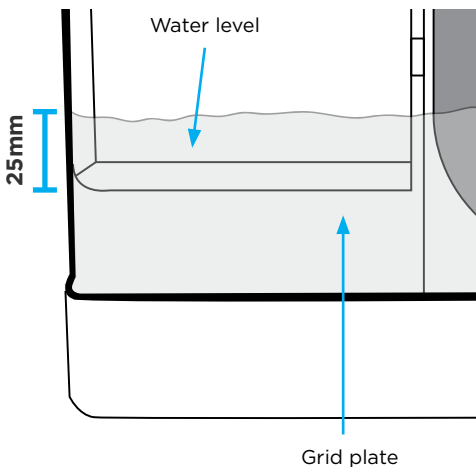

3 Initiate a backwash:

- a:** Using a Phillips head screwdriver push down on the actuator, and slowly turn CLOCKWISE until.
- b:** You hear a rush of water and air going to the drain.
- c:** When the cycle has finished (approx 9 mins), repeat the procedure, to initiate the next cycle and allow to finish.

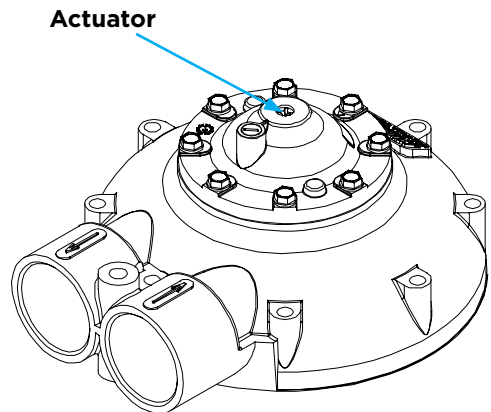

4 Add salt:

For convenience, the water softener has been designed to accommodate both block and tablet/pellet salt.

Block Salt:

To use salt blocks, simply place them in the salt compartment with the indents facing forwards.

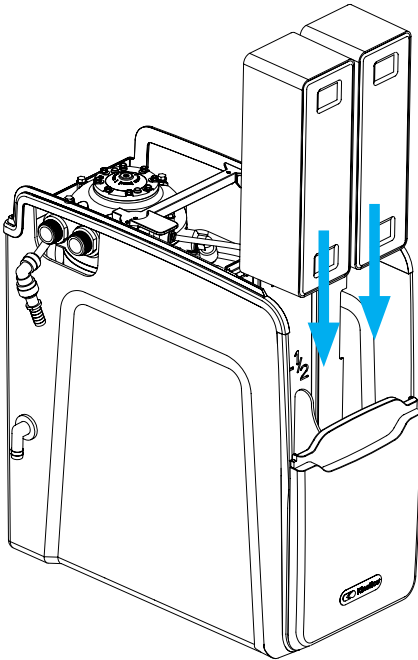

Tablet and Pellet Salt:

Simply pour into the salt compartment.

IMPORTANT:

Only use salt manufactured for use in water softeners.

Do not use rock or granular salt in your system. They contain impurities that can interfere with performance and could invalidate the Limited Warranty.

5 Fit the lid:

Replace the lids and check plumbing for any leaks. The installation is now complete.

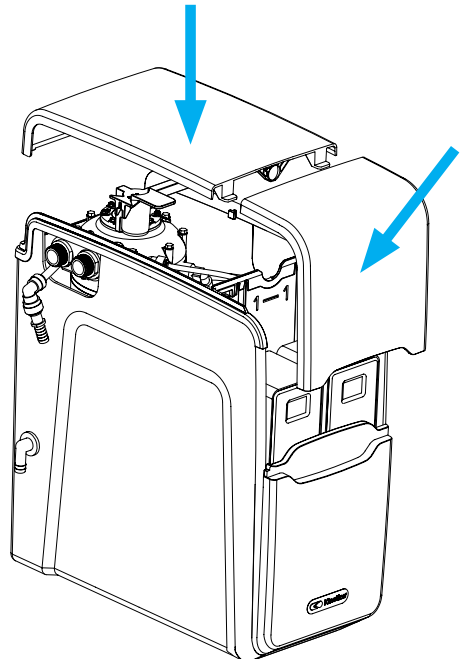

Useful information

1 Should water be present in the salt compartment?

Yes, it is normal to see water at a level of 25mm above the salt grid (see page 15). If water is not present to this level:

- a:** Fill the salt bay with water until the level is 25mm above the salt grid. Then conduct a manual regeneration.
- b:** To manually regenerate using a Phillips head screwdriver push down on the actuator, and slowly turn **CLOCKWISE ONLY** until the actuator tab has advanced the indicator dot to the word "BRINE".
- c:** You will hear a rush of water and air going to the drain.
- d:** When the vessel has finished its cycle (approx 12 mins), repeat the procedure, advance the indicator dot to the word "BRINE" in the next section and allow to finish (approx 12 mins).

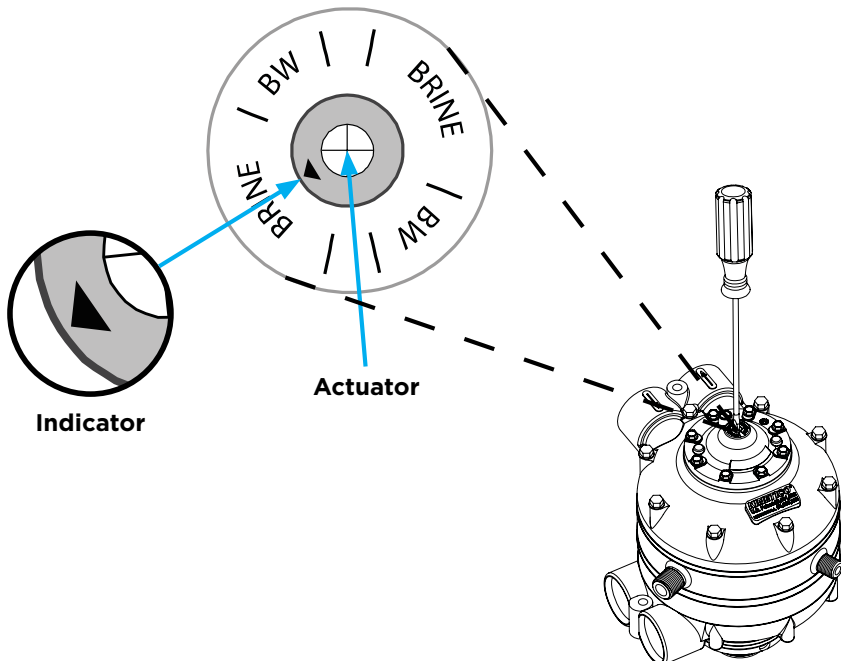

2 How do I correct the water level if it sits higher than the recommended 25mm above the salt grid?

Check that the brine valve is correctly held in place by the support bar and is seated firmly on the base of the cabinet.

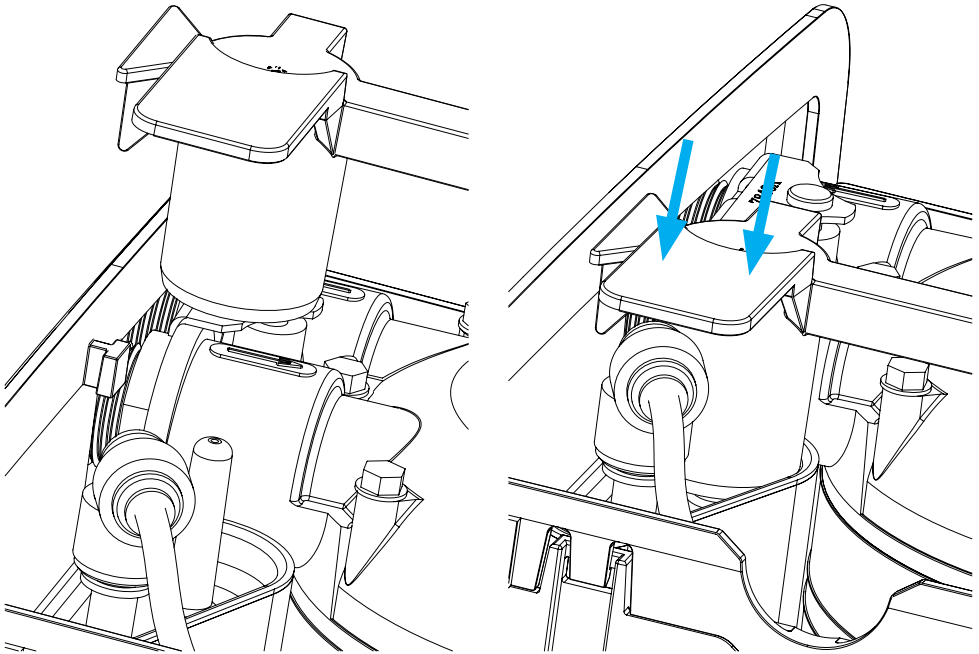

3 Why am I experiencing varying levels of hardness?

The softener will provide soft water immediately; however, until mains water has been displaced from the pipework, storage tanks and hot water system, you will experience varying degrees of hardness.

Depending on your water system and water usage, this may take a few weeks to clear.

It is also advisable to check that the by-pass valve is closed, when not using the Kinetico blending by-pass valve.